

Nähmaschinen-Ersatzteile

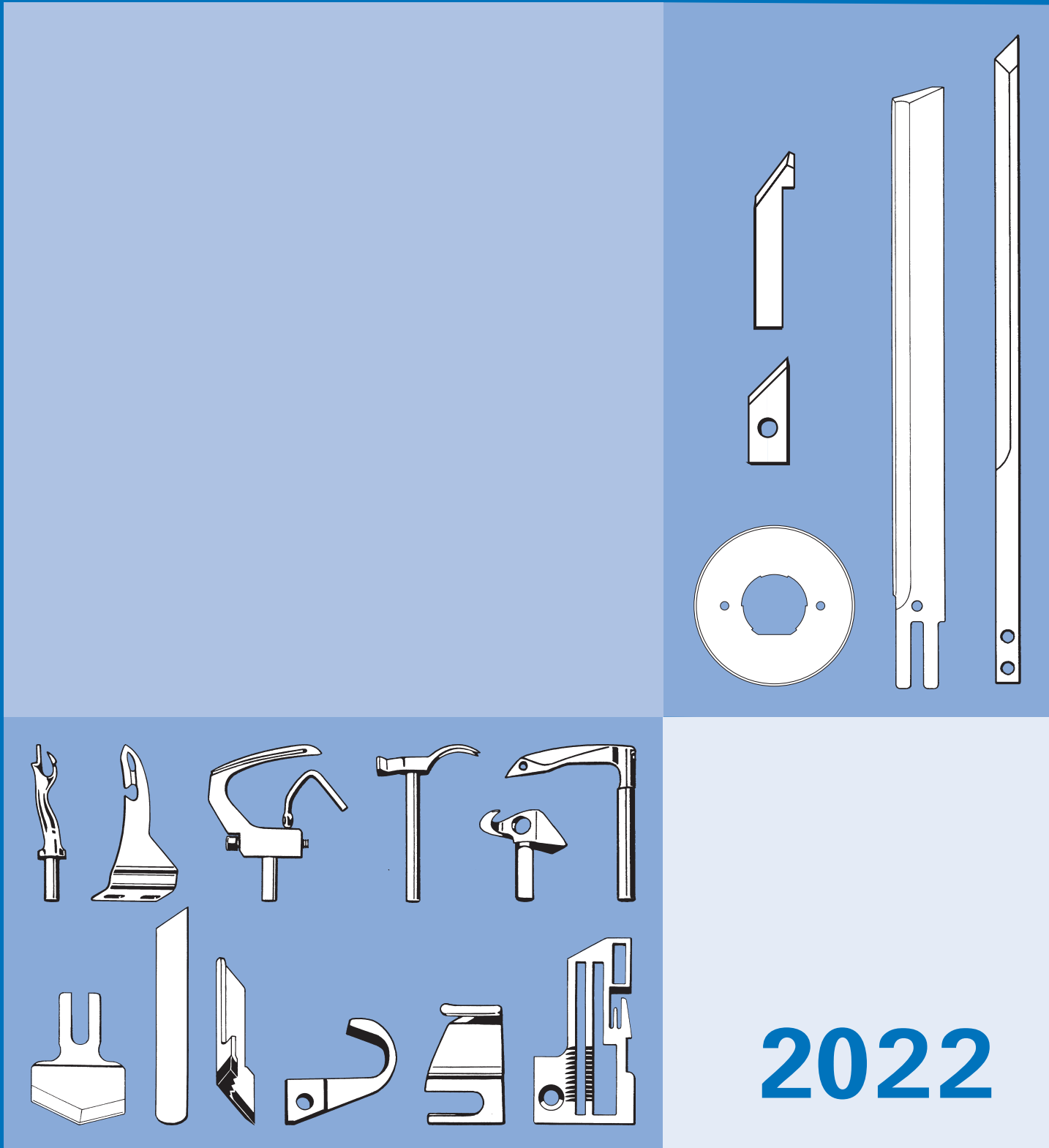





Sewingmachine Spare parts

Piezas de recambio para máquinas de coser

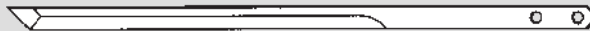







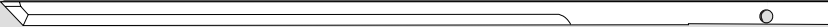

Bullmer

	105934	169 x 2,0 x 6
	103630	169 x 2,0 x 6 H hohl / hollow / hueco
	104264	201 x 2,5 x 8 G glatt / smooth / liso
	100124	201 x 2,5 x 8 H hohl / hollow / hueco
	104450	223 x 2,5 x 10 / 8
	105935	223 x 2,5 x 10 / 8 K kurzer Schnitt / short cut / corte corto
	103986	223 x 2,5 x 8 G glatt / smooth / liso
	102642	223 x 2,5 x 8 H hohl / hollow / hueco

F.K.



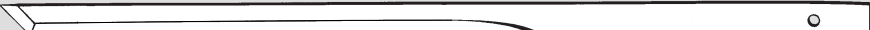



		291 x 2,5 x 8
---	--	---------------

Gerber

	G 93	175 x 1,5 x 6,3
	G 93 HPC / S 5200 1100880 / 054782004	195 x 2,0 x 7,9
	G 3000 / 3200 PN 07338700	202 x 2,1 x 6,3
	085878000 GTXL	206 x 1,9 x 7,9 / 6,4
	G 91 / G 93 / Z7 S 7200 / S 7500	254 x 2,35 x 8 Bohrung / hole / taladro
	G91 / S 93 / Z7 S 7200 / S 7500 02126109	254 x 2,35 x 8 Schlitz / slot / hendidura
	032419013	254 x 3,13 x 9,7 Heavy duty











Investronica

	CV 2	45,5 x 1,5 x 6,5
	SC 4 DIS, S 40 81700300	187 x 1,95 x 8
		245 x 2,52 x 8,3 / 7,8
	S 70817001301	245 x 3,0 x 8,3 / 7,8
	S 70817001 E 02	252 x 2,5 x 7,8 / 8,3
		291 x 2,52 x 7,85
	SC 2	296 x 2,52 x 8 K kurzer Schnitt / short cut / corte corto

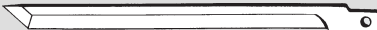
Kuris

		84 x 1,0 x 5
	ZAT 3 Nr. 24306	178 x 2,5 x 10
	TexCut Nr. 47968	227 x 3,0 x 10,5 / 9,0

Lectra

	Vector 2500	89 x 1,5 x 5,5
		89 x 1,5 x 5,5 / 3,5
	System 95	113 x 2,0 x 7,5 / 6
	System 95	113 x 2,0 x 7,5 / 6 H hohl / hollow / hueco
	System 95 Vector 500 / 5000	296 x 2,0 x 7
	System 95	296 x 3,0 x 8,5 / 6,5
		296 x 3,0 x 7
	116802 Vector 7000	360 x 2,4 x 7
	System 96 Vector 7000	360 x 3,0 x 8,5



Vollhartmetall Messer / Knives solid carbide / Cuchillas metal solide duro

Zünd



Z16



Z17



Z21



Z29



Z10



Z41



Z42



Z43

Comelz



HZ5K.S



HZ3B

Atom



01039999



01040445



Bullmer
107506T



Gerber
TL055



Gerber
92831000
Pivex 55 DEG



Lectra
F0495H













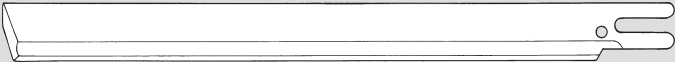
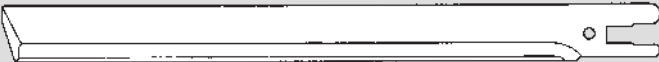
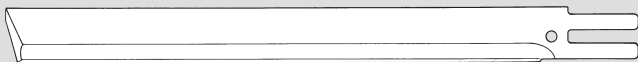

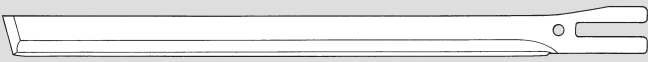
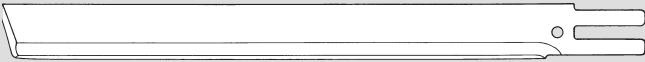
Setec

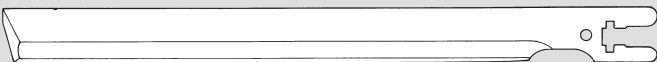
Alle Messer auch beschichtet verfügbar
 All knives coated available
 Disponibles todas las cuchillas recubiertas

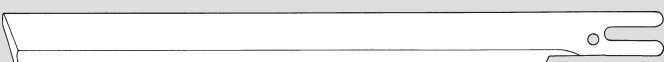

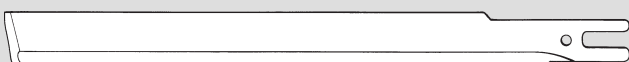
HSS-Stahl • High-Speed-Steel • Acero rápido de alto rendimiento

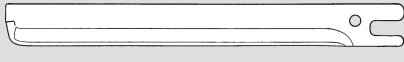
Abmessungen / Sizes /
Dimensiones:

	Beaver/Bullmer	6", 7", 9", 10"
	Comet/Gury	5", 6", 7", 8", 9", 10"
	Eastman/ Suprena	4", 5", 6", 7", 8", 9", 10", 11,5", 13", 14", 8" S 0335, 10" S 0352
	Eastman Servo Cutter 16,5	6", 10" gerade geschliffen = 16,5 mm ground straight at the back = 16,5 mm Lomo afilado recto = 16,5 mm
	Eastman Servo Cutter 14,3	6", 8", 9", 10" ausgeschliffen = 14,3 mm ground off at the back = 14,3 mm Lomo rectificado = 14,3 mm
	KM/Hoogs KS-AU	4", 5", 6", 7", 8", 9", 10", 11,5", 13"
	KM Automatik KS-EU	5", 6"
	Maimin	5", 6", 7", 8", 9", 10", 11,5"
	Maimin Servo Cutter	5", 6", 7", 8"
	Wolf	5", 6", 7", 8", 9", 11,5", 13"
	Kuris-KV	KVW 70 / 4" 15056 KV 90 / KVW 12 / 5" 15105 KV 115 / KVW 15 / 6" 15155 KV 140 / KVW 18 / 7" 15205 KVW 20 / 8" 15256
	Kuris-KV 4	KV 1100 / 6" 15383 KV 1350 / 7" 15382 KV 1600 / 8" 15380 KV 2000 / 10" 15381
	Kuris	KVS 700 15376
	Kuris	KVS 900 15389
	Kuris Servo Cutter	SC 700 / 4" 15388 SC 900 / 5" 14237 SC 1100 / 6" 14637 SC 1350 / 7" 14637 SC 1600 / 8" 14638 SC 2000 / 10" 17627

Sämtliche Messer auch konvex/gewellt verfügbar
All knives are also available as: convex/wavy
Todos las cuchillas también como edición convexo





Hoogs



**Kuris /
Maimin
Suprena**



Bullmer

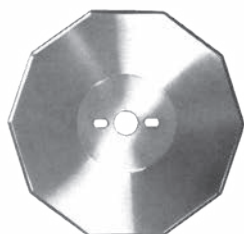

Bullmer

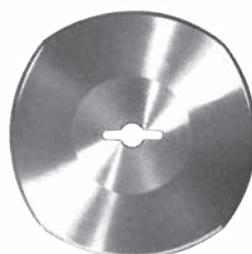

Hoogs

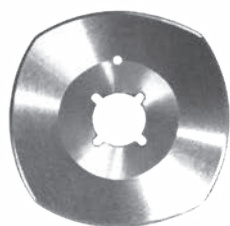

**Kuris /
Suprena**

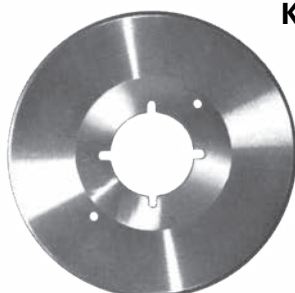

Kuris

Für Fabrikat For Machines Para producto	Messerform Shape of knives Forma de la cuchilla	Außen Ø Outer dia. Diámetro exterior mm	Bohrung Hole Espesor mm	Stärke Thickness Taladro mm
Type				

Bullmer

602	für 0250/1	10-kant	-sided	-cantos	50	14x8x2,5	1,0
604, 801	für 0470/1	10-kant	-sided	-cantos	59	10	1,0
601, 605	für 0570/1	10-kant	-sided	-cantos	79	10	2,0
607	für 0674/1	rund	round	circulares	100	10	1,5
606, 607, AV 300	für 0670/1	10-kant	-sided	-cantos	100	10	2,0
	für 675/1	4-Bogen	-curves	-arcos	100	10	2,0
	für 970	4-Bogen	-curves	-arcos	110	15	1,5
608, 609	für 840R	rund	round	ciculares	126	45	1,0
	für 870/1	10-kant	-sided	-cantos	126	45	1,0

Hoogs

Piccolo, Liliput, Favorit	MS-3	10-kant	-sided	-cantos	50	25x10x4	1,2
Piccolo, Liliput, Favorit	MS-2	4-Bogen	-curves	-arcos	50	25x10x4	1,2
Piccolo, Liliput, Favorit	MS-55	7-Bogen	-curves	-arcos	50	25x10x4	1,2
IAK, IAG, Goliath	MS-10	rund	round	circulares	60	25x10x4	1,2
IAK, IAG, Goliath	MS-11	4-Bogen	-curves	-arcos	60	25x10x4	1,2
IAK, IAG, Goliath	MS-12	10-Kant	-sided	-cantos	60	25x10x4	1,2
Z+St	MS-20	rund	round	circulares	110	25x10x4	1,3
Z+St	MS-21	4-Bogen	-curves	-arcos	110	25x10x4	1,3
Z+St	MS-22	10-Kant	-sided	-cantos	110	25x10x4	1,3
X-130, X-130-N	MS-28	rund	round	circulares	130	25x10x4	1,5
X-130, X-130-N	MS-29	4-Bogen	-curves	-arcos	130	25x10x4	1,5
X-130, X-130-N	MS-30	10-Kant	-sided	-cantos	130	25x10x4	1,5

Kuris

Novita	15780	rund	round	circulares	50	16	1,0
Novita	16110	6-Bogen	-curves	-arcos	50	16	1,0
Supernovita		rund	round	circulares	57	16	1,0
Supernovita		6-Bogen	-curves	-arcos	57	16	1,0
BOM 60	15752	rund	round	circulares	60	22	1,0
BOM 60	16002	4-Bogen	-curves	-arcos	60	22	1,0
BOM 30/80	15762	rund	round	circulares	80	22	1,0
BOM 30/80	16012	4-Bogen	-curves	-arcos	80	22	1,0
BOM 30/80	16092	6-Bogen	-curves	-arcos	80	22	1,0
BOM 30/80	16162	8-Bogen	-curves	-arcos	80	22	1,0
BOM 100/101	15772	rund	round	circulares	100	22	1,0
BOM 100/101	16022	4-Bogen	-curves	-arcos	100	22	1,0
BOM 100/101	16102	6-Bogen	-curves	-arcos	100	22	1,0
KRH 10	15712	rund	round	circulares	100	35	1,2
KRH 10	16042	4-Bogen	-curves	-arcos	100	35	1,2
KRH 12, KRT 120	15722	rund	round	circulares	120	35	1,2
KRH 12	16052	4-Bogen	-curves	-arcos	120	35	1,2
KRH 15	15732	rund	round	circulares	150	35	1,6
KRH 20	15742	rund	round	circulares	200	40	2,2
KRH 20	16172	4-Bogen	-curves	-arcos	200	40	2,2
Champion CRA	15802	rund	round	circulares	100	8	1,3

Gegenschneidklingen siehe Seite 138
Counterknives see page 138
Contracuchillas véase página 138



Eastman



Maimin

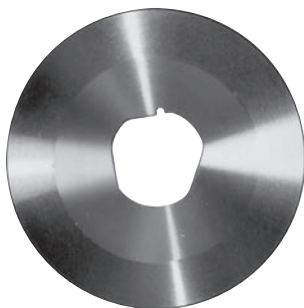

Wolf

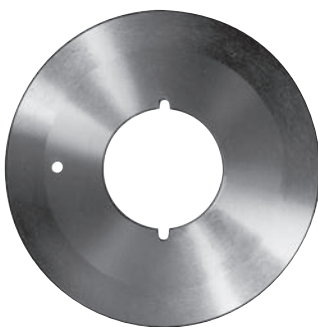

Rasor



Für Fabrikat For Machines Para producto	Messerform Shape of knives Forma de la cuchilla	Außen Ø Outer dia. Diámetro exterior	Bohrung Hole Espesor	Stärke Thickness Taladro
Type		mm	mm	mm

Eastman

080 C 01-147	2 1/4"	Chickadee	rund	round	circulares	57	16	
26	3 1/2"		rund	round	circulares	90	28	
59	4"	Falcon IV, Track, Robin	rund	round	circulares	101,6	40	
101	5"		rund	round	circulares	127	40	
61	5 1/4"	548/355-61	rund	round	circulares	133,6	51	
39	6"	548/562/567	rund	round	circulares	152,6	51	

Maimin

Minishear 2"			rund	round	circulares	50	16	
Minishear 2"			6-Bogen	-curves	-arcos	50	16	
Minishear 2"			8-Bogen	-curves	-arcos	50	16	
ACD	2 1/2"		rund	round	circulares	63,3	21,6	1,0
ACDC	6"		rund	round	circulares	152,5	58,2	1,4
ACDC	7"		rund	round	circulares	178		

Suprena

M702			rund	round	circulares	50	16	
M700			6-Bogen	-curves	-arcos	50	16	
M703			8-Bogen	-curves	-arcos	50	16	
R742			rund	round	circulares	80	22	
R1512			rund	round	circulares	100	22	
R1514			4-Bogen	-curves	-arcos	100	22	
R1513			6-Bogen	-curves	-arcos	100	22	

Wolf

PUP	25260		4-Bogen	-curves	-arcos	52,5	17,6	1,0
SRN	2 1/2"		rund	round	circulares	64		1,0
Clipper	4"	23 einfasig	rund	round	circulares	102	31,75	1,0
Clipper	4"	23 zweifasig	rund	round	circulares	102	31,75	1,0
Clipper	4 3/4"	22	rund	round	circulares	121	42,5	1,0
Blazer	5 1/4"	21	rund	round	circulares	134	42,5	1,0
SLIM JIM	5 1/4"	24	rund	round	circulares	134	50	1,0
Blazer-0	6"	18	rund	round	circulares	153	50,8	1,2
BIG-0	10"		rund	round	circulares	254	50,8	1,7

Diverse

Allstar 100 AS-1026			6-Bogen	-curves	-arcos	50	12,7	
KM RS 100			rund	round	circulares	100	21	
KM RS 100 OCTA			8-Bogen	-curves	-arcos	100	21	
Rasor Extra 86 C			rund	round	circulares	86	22,4	
Rasor Extra D 100 C			rund	round	circulares	100	22,4	
SULEE Modell 260			=Hoogs Z+St					
			rund	round	circulares	110		
Miniroller			4-Bogen	-curves	-arcos	110	25x10x5	
Secat			rund	round	circulares	67	22,4	1,0
Secat			10-Kant	-sided	cantos	67	22,4	1,0

Weitere Kreismesser fertigen wir nach Muster oder Zeichnung
We produce further knives according to sample or drawing
Producimos más cuchillas circulares según muestra o dibujo

Alle Messer sind auch in HSS verfügbar
All knives are available in High-Speed-Steel
Todos las cuchillas también en acero rápido de alto rendimiento



Bullmer

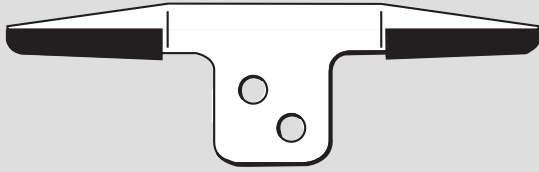

014694



014245

Hoogs



UM-5

501-138-UM-5 Klasse ST-1
200-130-UM-5 Klasse ZN-ZVN
512-110-UM-5 Klasse ST 565

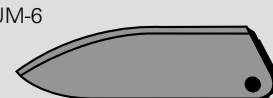

UM-6

501-135-UM 6
Klasse ST 2000 / 5000

Kuris



02 257

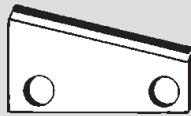

22 219 (CT)



31 391 (CT)



25 208 (CT)
Suprena M 460 / 706



30 785 (CT)
Suprena M 456, M 458



Für alle Bandmesser-Zuschneidemaschinen
z.B. Kuris, Hoogs, Bullmer, Wastema, Hitaka,
CKS, NCA, Takaoka usw.
10–20 mm breit,
0,45 mm stark,
in verschiedenen Schliffarten
(siehe unten).

For all band knife cutting machines, e.g.
Kuris, Hoogs, Bullmer, Wastema, Hitaka,
CKS, NCA, Takaoka etc.
10–20 mm wide
0,45 mm thick
in various grinding versions
(see below).

Para todas las máquinas cortadoras
de cuchilla cinta p.e. Kuris, Hoogs, Bullmer,
Wastema, Hitaka, CKS, NCA, Takaoka etc.
Ancho 10–20 mm,
espesor 0,45 mm
varios afilados
(véase abajo).

Hergestellt aus erstklassigem Material,
lieferbar als Meterware oder in Endloslängen
(Fixlängen).

Manufactured of first-class material,
available in metrages or endless length
(fix length)

Hechas de materiales de primera clase, de
ser entragadas por metro o en largos conti-
nuos (largos fijos).

glatt
smooth
liso

gezahnt
serrated
dentado

gezahnt 2,5 mm
serrated 2,5 mm
dentado 2,5 mm

konkav
concave
cóncavo

konvex
convex
convexo

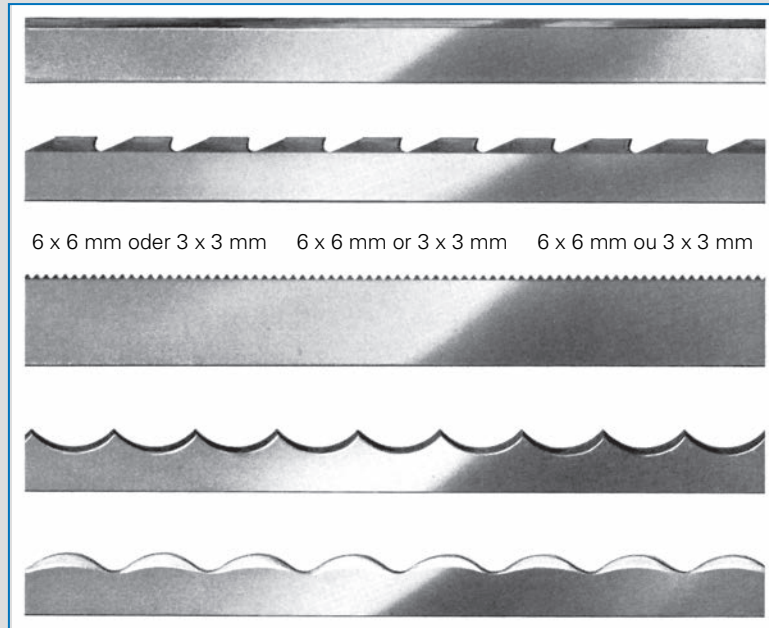

Doppelte Wate
Double bevel
Biselado doble



Vierfach Wate
Four bevels
Biselado cuádruplo

Gebräuchliche Abmessungen: glatt, doppelte Wate
Usual dimensions: smooth, double bevel
Dimensiones en uso: liso, biselado doble

2400 x 10 x 0.45	3605 x 10 x 0.45	4200 x 10 x 0.45	4810 x 10 x 0.45
2430 x 10 x 0.45	3680 x 10 x 0.45	4210 x 10 x 0.45	4850 x 10 x 0.45
2450 x 10 x 0.45	3700 x 10 x 0.45	4210 x 15 x 0.45	4850 x 15 x 0.45
2880 x 10 x 0.45	3720 x 10 x 0.45	4240 x 10 x 0.45	4900 x 10 x 0.45
2900 x 10 x 0.45	3750 x 10 x 0.45	4250 x 10 x 0.45	4920 x 10 x 0.45
2945 x 10 x 0.45	3760 x 10 x 0.45	4350 x 10 x 0.45	4920 x 15 x 0.45
3000 x 10 x 0.45	3840 x 10 x 0.45	4400 x 10 x 0.45	5030 x 10 x 0.45
3050 x 10 x 0.45	3850 x 10 x 0.45	4450 x 10 x 0.45	5050 x 10 x 0.45
3100 x 10 x 0.45	3860 x 10 x 0.45	4460 x 10 x 0.45	5070 x 10 x 0.45
3100 x 15 x 0.45	3870 x 10 x 0.45	4500 x 10 x 0.45	5150 x 10 x 0.45
3120 x 10 x 0.45	3880 x 10 x 0.45	4530 x 10 x 0.45	5200 x 10 x 0.45
3150 x 10 x 0.45	3900 x 10 x 0.45	4550 x 10 x 0.45	5207 x 12 x 0.45
3240 x 10 x 0.45	3900 x 15 x 0.45	4550 x 15 x 0.45	5210 x 10 x 0.45
3300 x 10 x 0.45	3950 x 10 x 0.45	4555 x 10 x 0.45	5230 x 10 x 0.45
3360 x 10 x 0.45	3960 x 10 x 0.45	4560 x 10 x 0.45	5270 x 10 x 0.45
3380 x 10 x 0.45	4020 x 10 x 0.45	4600 x 10 x 0.45	5280 x 10 x 0.45
3400 x 10 x 0.45	4040 x 10 x 0.45	4620 x 10 x 0.45	5285 x 10 x 0.45
3420 x 10 x 0.45	4050 x 10 x 0.45	4650 x 10 x 0.45	5300 x 10 x 0.45
3460 x 10 x 0.45	4080 x 10 x 0.45	4690 x 10 x 0.45	5300 x 12 x 0.45
3470 x 10 x 0.45	4094 x 10 x 0.45	4700 x 10 x 0.45	5300 x 15 x 0.45
3480 x 10 x 0.45	4100 x 10 x 0.45	4745 x 10 x 0.45	5500 x 10 x 0.45
3500 x 10 x 0.45	4100 x 12 x 0.45	4750 x 10 x 0.45	5800 x 15 x 0.45
3530 x 10 x 0.45	4115 x 12 x 0.45	4750 x 12 x 0.45	5840 x 10 x 0.45
3540 x 10 x 0.45	4120 x 10 x 0.45	4750 x 15 x 0.45	6040 x 10 x 0.45
3550 x 10 x 0.45	4130 x 10 x 0.45	4800 x 10 x 0.45	
3600 x 10 x 0.45	4150 x 10 x 0.45	4800 x 15 x 0.45	



Die Schmirgelschnur ist: Features of the abrasive cord:

- flexibel / flexible
- abriebfest / resistant to abrasion
- verschleißarm / wear resisting
- geruchsneutral / odourless
- bruchfest / break-proof
- gleichmäßig im Durchmesser
constant diameter

			Abrasive cords Standard Schmirgelschnur Standard cord		Silizium Carbide cords Feinere Struktur finer structure		Polisher cords zum Polieren for polishing		Oxyd Polisher cords zum Feinstpolieren for finest polishing	
Ø mm	Ø Zoll/Inch		Bestell-Nr. Order No.	Körnung Grain	Bestell-Nr. Order No.	Körnung Grain	Bestell-Nr. Order No.	Körnung Grain	Bestell-Nr. Order No.	Körnung Grain
Rollen/Spools 15 m:										
66	0,3	0,012			1SC/15	280	1PC/15	280		
60	0,4	0,015	2AC/15	280	2SC/15	280	2PC/15	280		
55	0,5	0,019	3AC/15	240	3SC/15	240	3PC/15	280	3OX/15	Oxyd
54HS	0,6	0,023	4AC/15	240	4SC/15	240	4PC/15	280	4OX/15	Oxyd
	0,7	0,027	5AC/15	240	5SC/15	240	5PC/15	280	5OX/15	Oxyd
54	0,8	0,031	7AC/15	180	7SC/15	180	7PC/15	280	7OX/15	Oxyd
53	1,0	0,039	8AC/15	180	8SC/15	180	8PC/15	280	8OX/15	Oxyd
	1,2	0,047	12AC/15	150	12SC/15	150	12PC/15	280	12OX/15	Oxyd
52/51	1,4	0,055	14AC/15	150	14SC/15	150	14PC/15	280	14OX/15	Oxyd
50	1,8	0,071	18AC/15	120	18SC/15	120	18PC/15	280	18OX/15	Oxyd
49	2,1	0,082	21AC/15	120	21SC/15	120	21PC/15	280		
Rollen/Spools 50 m: (1,4 und 1,8 mm Ø = 25 m)										
66	0,3	0,012			1SC/50	280				
60	0,4	0,015	2AC/50	280	2SC/50	280	2PC/50	280		
55	0,5	0,019	3AC/50	240	3SC/50	240	3PC/50	280		
54HS	0,6	0,023	4AC/50	240			4PC/50	280		
	0,7	0,027	5AC/50	240			5PC/50	280		
54	0,8	0,031	7AC/50	180	7SC/50	180	7PC/50	280		
53	1,0	0,039	8AC/50	180	8SC/50	180				
	1,2	0,047	12AC/25	150						
52/51	1,4	0,055	14AC/25	150						
50	1,8	0,071								